

STACKMAX

PALLETIZING SIMPLIFIED



Palletize loads up to
360 lbs (165 kg)

Securely Stack:

Boxes
Bags
Trays
Kegs
Pails
Bails

Almost Anything!

RAISE the level of your production processes with our end of line palletizing solutions.

Reduce

your dependency
on manual labor

Accelerate

your **ROI**

Increase

production up-time,
productivity, quality

Simplify

and compress
implementation

Eliminate

costly repetitive
motion injuries

MAX_80M_2P_1C_TS_SZ_SO

Palletize 1 product to 2 positions

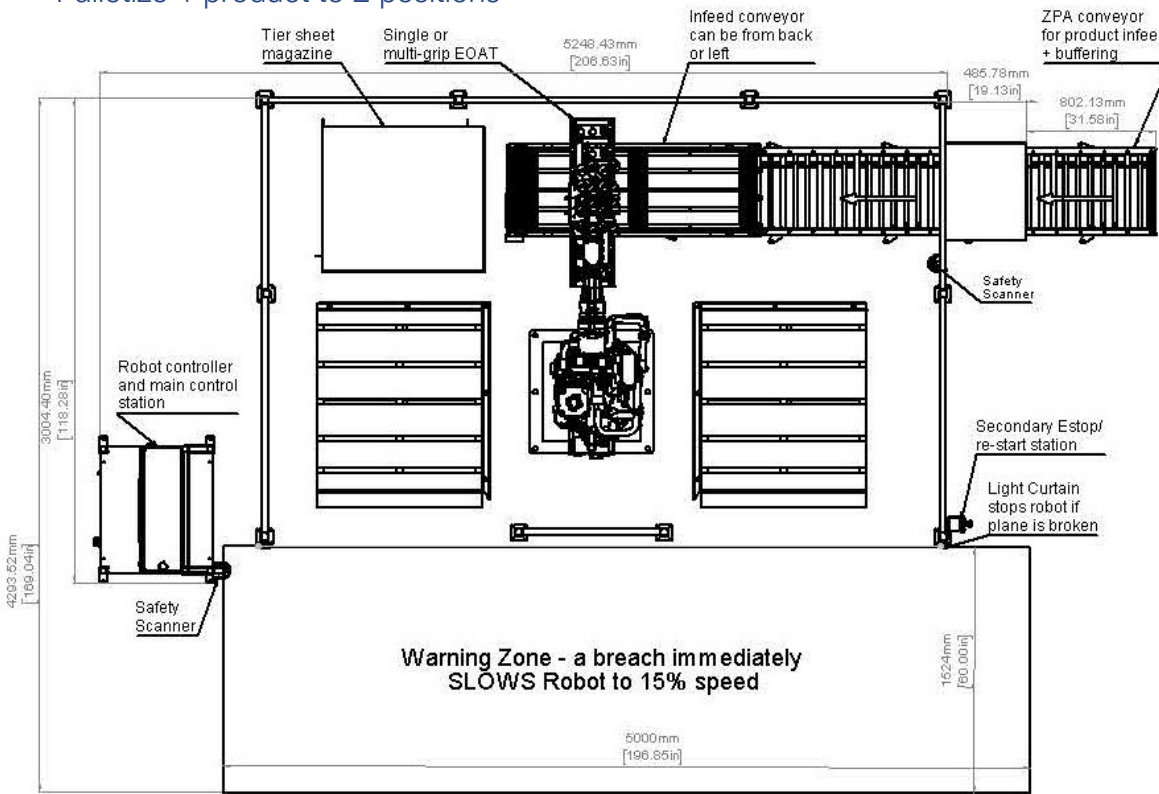

BASIC SPECIFICATIONS

FOOT PRINT
21.5 x 14 ft (655 x 427cm)
includes warning zone (*80M)

MANUAL LOADING
Manual pallet placement and removal

PALLET TYPES
GMA, CHEP, Custom almost any size

STACKING HEIGHT
Up to 68" (MAX_80M)
Up to 102" (MAX_190M)

LOAD CAPACITY
*80M - to 165 lbs (75kg)
*190M - to 360 lbs (165kg)

POWER REQUIREMENTS
460 VAC 3P 25A (*80M)
460 VAC 3P 30A (*190M)
Other options available

WE CONFIGURE THE OPTIMUM LAYOUT FOR YOUR SPECIFIC NEEDS FROM OUR ASSORTMENT OF PRE-ENGINEERED PRODUCTS

MAX_80M_2P_2C_TS

Palletize 2 products to two positions

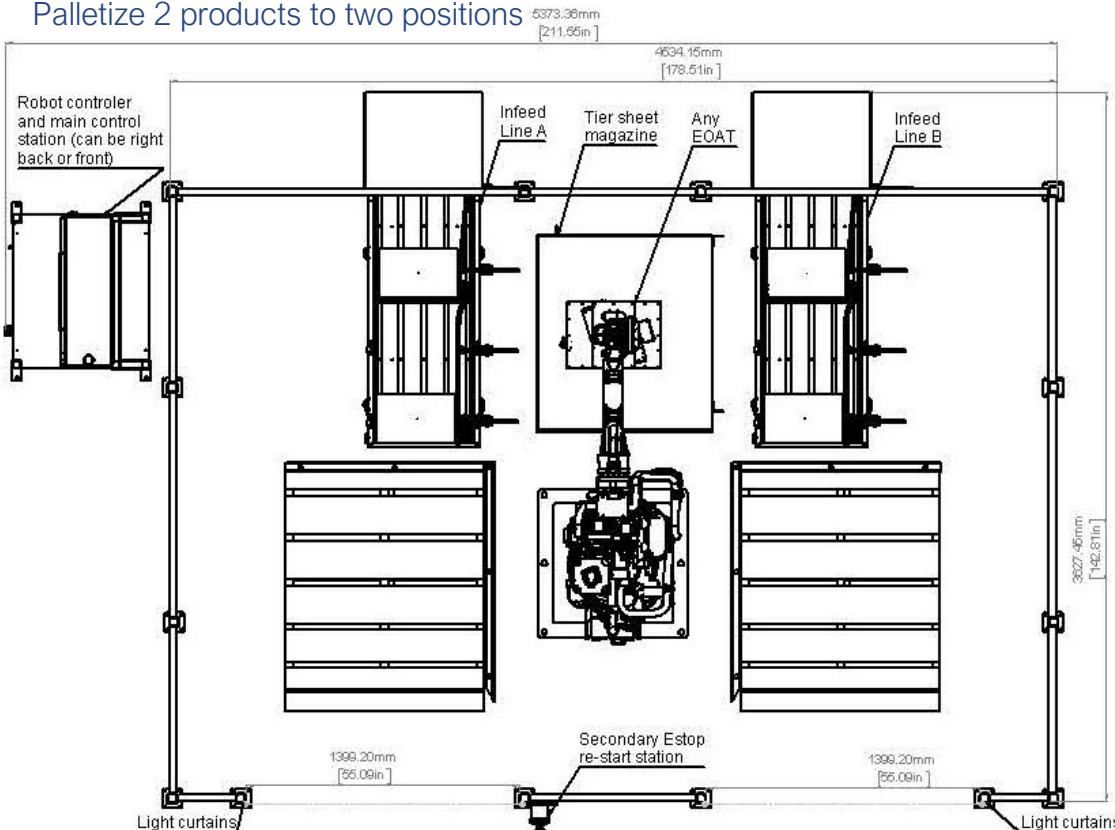

BASIC SPECIFICATIONS

FOOT PRINT
14.9 x 11.9 ft (454 x 363 cm)
(*80M)

LOADING
Manual pallet placement and removal

PALLET TYPES
GMA, CHEP, Custom almost any size

STACKING HEIGHT
Up to 68" (MAX_80M)
Up to 102" (MAX_190M)

LOAD CAPACITY
*80M - to 165 lbs (75kg)
*190M - to 360 lbs (165kg)

POWER REQUIREMENTS
460 VAC 3P 25A (*80M)
460 VAC 3P 30A (*190M)
Other options available

MAX.C_80A_1P_1C_PD_TS_MVG2

Palletize 1 product to 1 position - Fully automated & compact

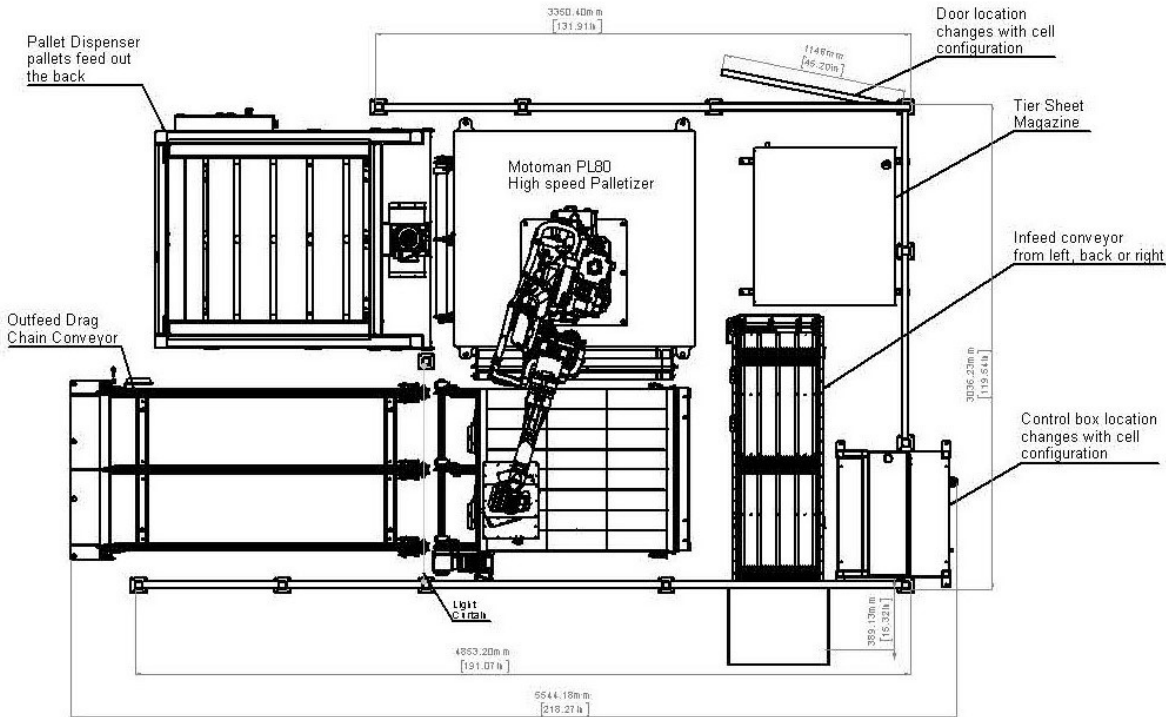

BASIC SPECIFICATIONS

FOOT PRINT
15.9 x 10 ft (484 x 305 cm)
Fully AUTOMATED (*80A)

AUTO PALLET HANDLING
Load dispenser remove fully loaded pallets from end

PALLET TYPES
GMA, CHEP, 48 x 40
Customization available

STACKING HEIGHT
Up to 68" (MAX_80A)

LOAD CAPACITY
*80A - to 165 lbs (75kg)

POWER REQUIREMENTS
460 VAC 3P 30A (*80A)
Other options available

MAX_80A_1P_1C_PD_TS_MVG2_SO

Palletize 1 product to 1 position - Fully automated, multi-zone pallet conveyor

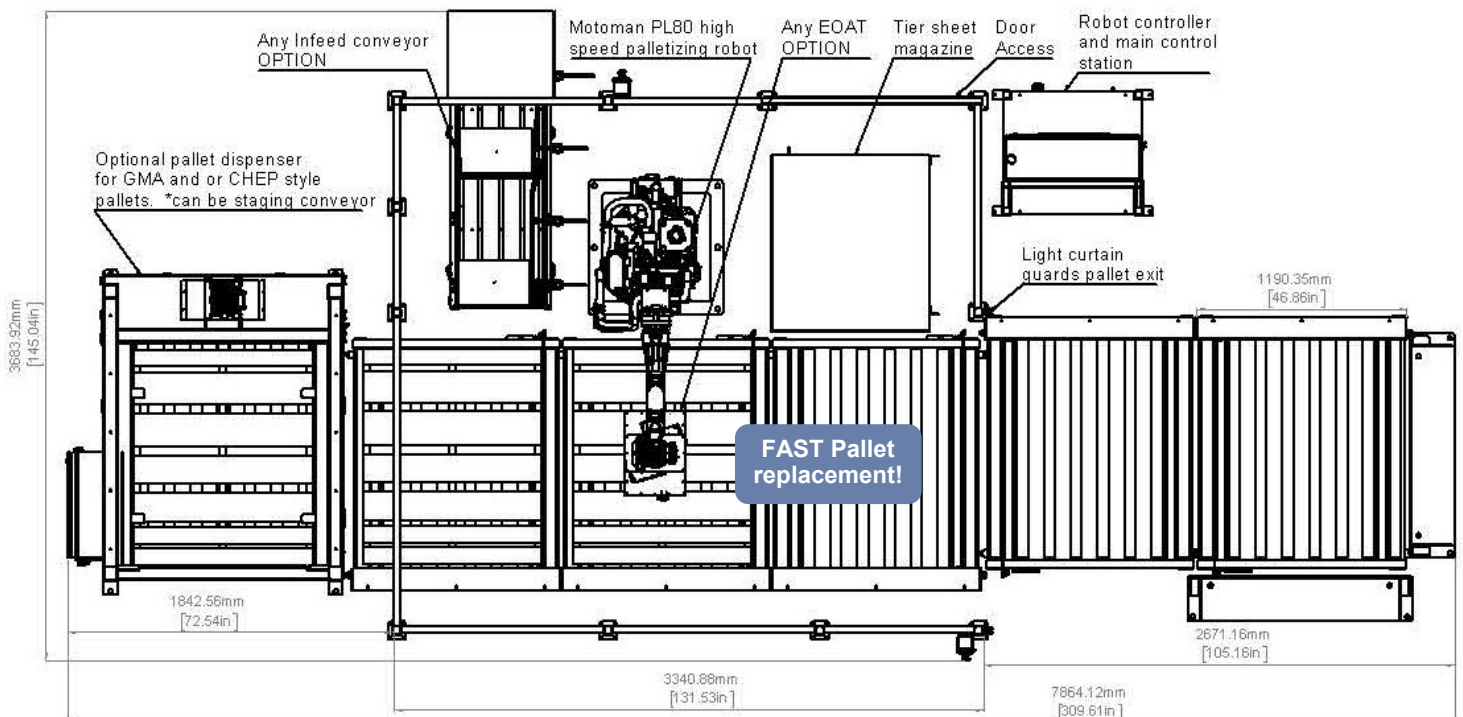

BASIC SPECIFICATIONS

FOOT PRINT
25.8 x 12.1 ft (786 x 368 cm)
Fully AUTOMATED (*80A)

STACKING HEIGHT
Up to 68" (MAX_80A)

AUTO PALLET HANDLING
Load dispenser remove fully loaded pallets from end

LOAD CAPACITY
*80A - to 165 lbs (75kg)
*190A - to 360 lbs (165kg)

PALLET TYPES
GMA, CHEP, 48 x 40
Customization available

POWER REQUIREMENTS
460 VAC 3P 30A (*80A)
Other options available

STANDARD SPECIFICATIONS (across the STACKMAX offering)



CLASS 4 SAFETY

Safety Controller monitors Estops, light curtains, scanner, and door interlocks

ELECTRICAL ENCLOSURE

Built to UL / CSA / CE specs.
Certification available

END OF ARM TOOLING (EOAT)

1, 2 and multi-box vacuum grippers
Box clamping, Clamshell bag gripping,
fork support, and more

PALLET BUILDER SOFTWARE
Yaskawa NO-CODE PALLETIZING
PLATFORM. Expands smart
pendent capability for palletizing
tasks

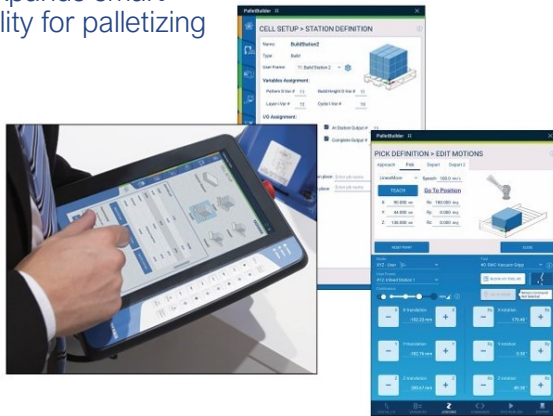

GUARDING

Safety fencing, with 2 x 2 wire mesh
screening, floor anchored (72" tall)

COMPRESSED AIR

11-22 scfm @ 80 psi (std. tools)
3 scfm @ 60 psi (blower systems)
3-5 scfm @ 60 psi (clamp tools)

WARRANTY

1 year parts and service
Optional multi-year available
Remote support—extends warranty to 3
years parts and limited service

HMI

Siemens, or Maple 12" touch screen
UL listed. AB available

CONVEYOR OPTIONS

Infeed conveyors for single and multi-pick
CDLR and Drag chain pallet conveyors

OPERATING ENVIRONMENT

40-90° F (4-32° C)

REMOTE SUPPORT

System available
Our team becomes an extension of
your support network.

You know you need to automate your palletizing
processes, BUT you:

- Don't have time?
- Don't have the manpower?
- Don't know where to begin?
- Think it is too expensive?

We focus on the details so you don't have to.
Our configurable palletizing systems reduce cost
to maximize your **ROI**.

ROI INDUSTRIES GROUP



A FULL SPECTRUM
OF CONFIGURABLE
PALLETIZING
SOLUTIONS



STACKBOT



PALLET POD



STACKMAX

CAPACITY	55 lbs (25 kg)	220 lbs (100 kg)	Up to 415 lbs (190 kg)
SPEED	Up to 7 c/min	Up to 24 c/min	Up to 50 c/min
MOBILITY	Leveling casters + hoist rings	Fork pockets + wheels + pads	Floor Anchored
INSTALLATION	1 hr	2-4 hrs	1-3 days
POWER	208-240 1p 15A	208-230 3p 20A 460-480 3p 12A	230 or 480 3p up to 40 Amps
COST	\$\$	\$\$	\$\$\$

241021.V10